



## SUBMITTAL DATA

GWH09ATCXB-A3DNA3A/I / GWH09ATCXB-A3DNA1A/O  
9000 BTU/H Wall Mounted Heat Pump System

Job Name

Location

Date

Purchaser

Engineer

Submitted to

For

Unit Designation

Schedule No.



YAP1F7F



GWH09ATCXB-A3DNA3A/I



GWH09ATCXB-A3DNA1A/O



XE71 (Optional)

## GENERAL FEATURES

- AHRI Certificate: [209271944](#)
- High Efficiency DC Inverter Technology
- Compact and Quiet Design
- Wireless Remote with LCD Display
- Wired Controller Options
- 10 Years Parts Warranty
- Wi-Fi Included
- Low Ambient Cooling down to 0°F (Range 0°F to 115°F)
- Low Ambient Heating down to -13°F (Range -13°F to 75°F)
- Coil (Indoor and Outdoor) Copper Tube / Aluminum Fin
- Blue Colored Fin - 500 Hrs Salt Spray Tested

## SPECIFICATIONS, FEATURES & FUNCTION SUMMARY

SPECIFICATIONS		GWH09ATCXB-A3DNA3A		FEATURES & FUNCTIONS SUMMARY		GWH09ATCXB-A3DNA3A	
System Type		HEAT PUMP					
<b>SYSTEM PERFORMANCE</b>							
Cooling	Min - Max	Btu/h	3000 - 11000				
	Capacity @95°F	Btu/h	9100				
Heating	Min - Max	Btu/h	10000 (2200 - 13000)				
	Capacity @5°F	Btu/h					
	Capacity @17°F	Btu/h	6000				
	Capacity @47°F	W	10000				
SEER2				19.5			
EER2				11.3			
HSPF/HSPF2				9.8/8.6			
COP @5°F				3.6			
COP @47°F							
Cooling Temperature Range		°F	0 - 115				
Heating Temperature Range		°F	-13 - 75				
Refrigerant Type				R410A			
<b>INDOOR UNIT</b>				GWH09ATCXB-A3DNA3A/I			
Air flow (Min-Max)		CFM	159 - 353				
Sound Pressure Level (Min - Max)		dB(A)	26 - 41				
Dehumidification		pt/hr	1.69				
External Dimensions (WxHxD)		in	32-7/8 x 10-7/8 x 7-7/8				
Package Dimension (W x H x D)		in	35-1/4 x 13-5/8 x 10-11/16				
Net Weight		lbs	19.8				
Gross Weight		lbs	24.3				
<b>OUTDOOR UNIT</b>				GWH09ATCXB-A3DNA1A/O			
Compressor Type				GREE G-10 / 2 - STAGE INVERTER			
Sound Pressure Level		dB(A)	51				
External Dimensions (W x H x D)		in	28-13/16 x 21-7/8 x 13				
Package Dimension (W x H x D)		in	31-5/16 x 24-3/4 x 14-13/16				
Net Weight		lbs	59.5				
Gross Weight		lbs	65.0				
<b>REFRIGERANT PIPING</b>							
Refrigerant Charge - R410A		oz	24.4				
Additional Charge		oz/ft	0.2				
Line Set Size (Liquid - Gas) - Flared Connections		in	1/4 - 3/8				
Pre-Charge Length		ft	25				
Pipe Length (Min - Max)		ft	10 - 66				
Max. Pipe Elevation		ft	39				
<b>ELECTRICAL</b>				115V / 1Ph /60Hz			
Power Supply				115V / 1Ph /60Hz			
Voltage Range (Min - Max)		VAC	103 - 127				
Rated Current - Cooling		A	17.5				
Rated Current - Heating		A	18				
MCA		A	16				
MOCP		A	20				
Suggested Breaker Size		A	20				
Main Power Wire Size		AWG	Per Local Code				
Interconnecting Wire Size		AWG	14 / 4				
<b>SYSTEM FEATURES</b>							
Inverter Type				G10			
Ultra Low Frequency Torque Control				Yes			
Power Factor Correction				Yes			
Compressor Type				High Efficiency Rotary			
Refrigerant Type				R410A			
Basepan With Electric Heater				Yes			
Compressor With Electric Heater				Yes			
Outdoor Fin Coating (Color:Blue)				Acrylic-Resin/Anti-Corrosive			
Intelligent Defrosting				Yes			
Force Defrosting				Yes			
Intelligent Preheating				Yes			
Low Voltage Startup				Yes			
Memory/Power Failure Recovery				Yes			
Self Diagnosis				Yes			
Wired Controller Interface (XE71)				Yes			
WiFi Included				Yes			
Indoor Fan Type				Crossflow			
Multi Fan Speeds				4 Speeds			
Indoor Unit Display				Yes			
Auxiliary Electrical Heater				No			
Ventilation (Outdoor Air)				No			
<b>REMOTE CONTROLLER FUNCTIONS</b>							
Auto Mode				Yes			
Auto Fan				Yes			
Manual Horizontal Swing				Yes			
Auto Swing (Vertical Auto Swing)				Yes			
Clock on Remote Controller				Yes			
Dry Mode				Yes			
Dry Anti-Mildew (X-Fan) Mode				Yes			
Energy Saving Mode				Yes			
Dirty Filter Alert				No			
I Feel Function				Yes			
Lock on Remote Controller				Yes			
Quiet Mode				No			
Room Temperature Display				Yes			
Sleep Mode				Yes			
Timer Mode				Yes			
Turbo Mode				Yes			
Display On/Off Control				Yes			
Freeze Guard Mode (46°F)				Yes			
Display On/Off Control				Yes			

## DIMENSIONS

### INDOOR UNIT

Unit: inch

GWH09ATCXB-A3DNA3A/I

#### DIMENSIONS

W	32-7/8
H	10-7/8
D	7-7/8
W1	7-3/64
W2	18-5/32
W3	7-11/16

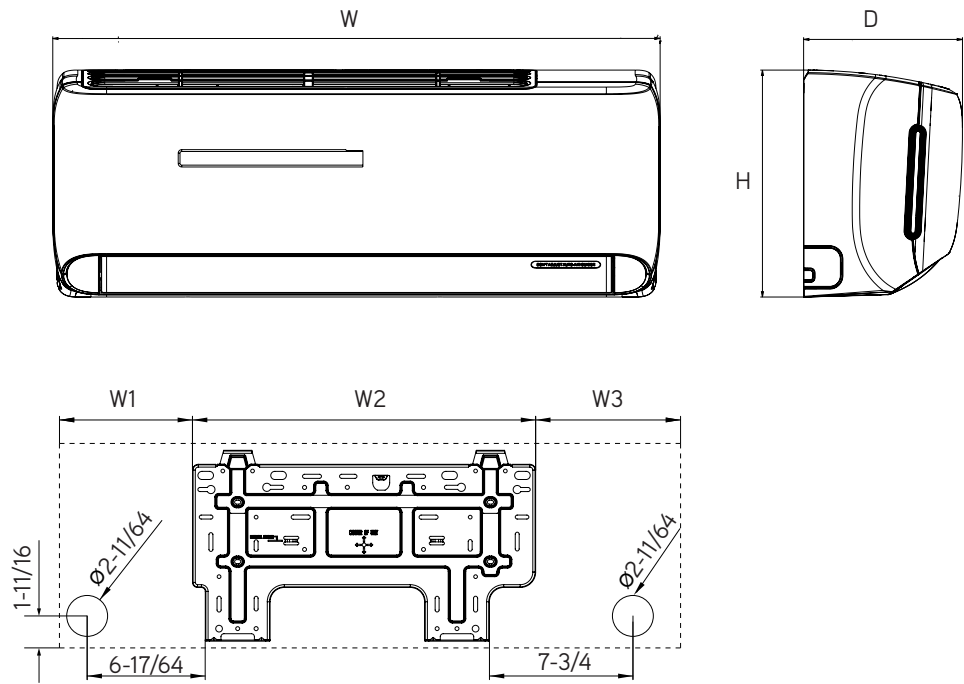

### OUTDOOR UNIT

Unit: inch

GWH09ATCXB-A3DNA1A/O

#### DIMENSIONS

A	26-37/64
B	28-13/16
C	21-7/8
D	11-7/32
E	13
F	17-29/32
G	12-13/64

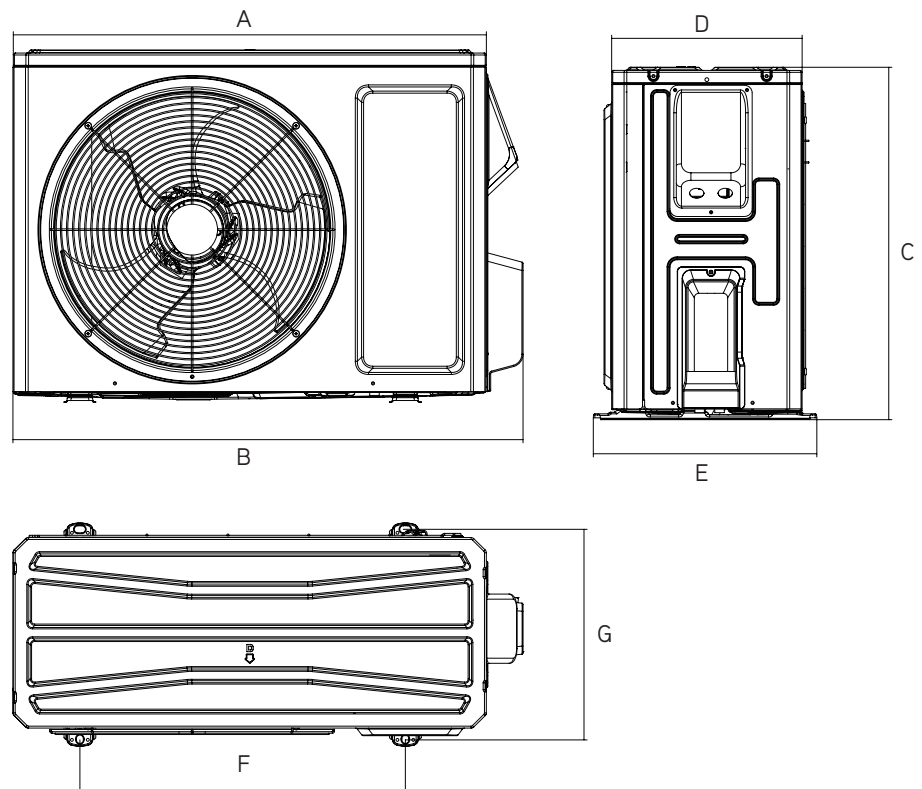

# CLEARANCES

## INDOOR UNIT Minimum clearance

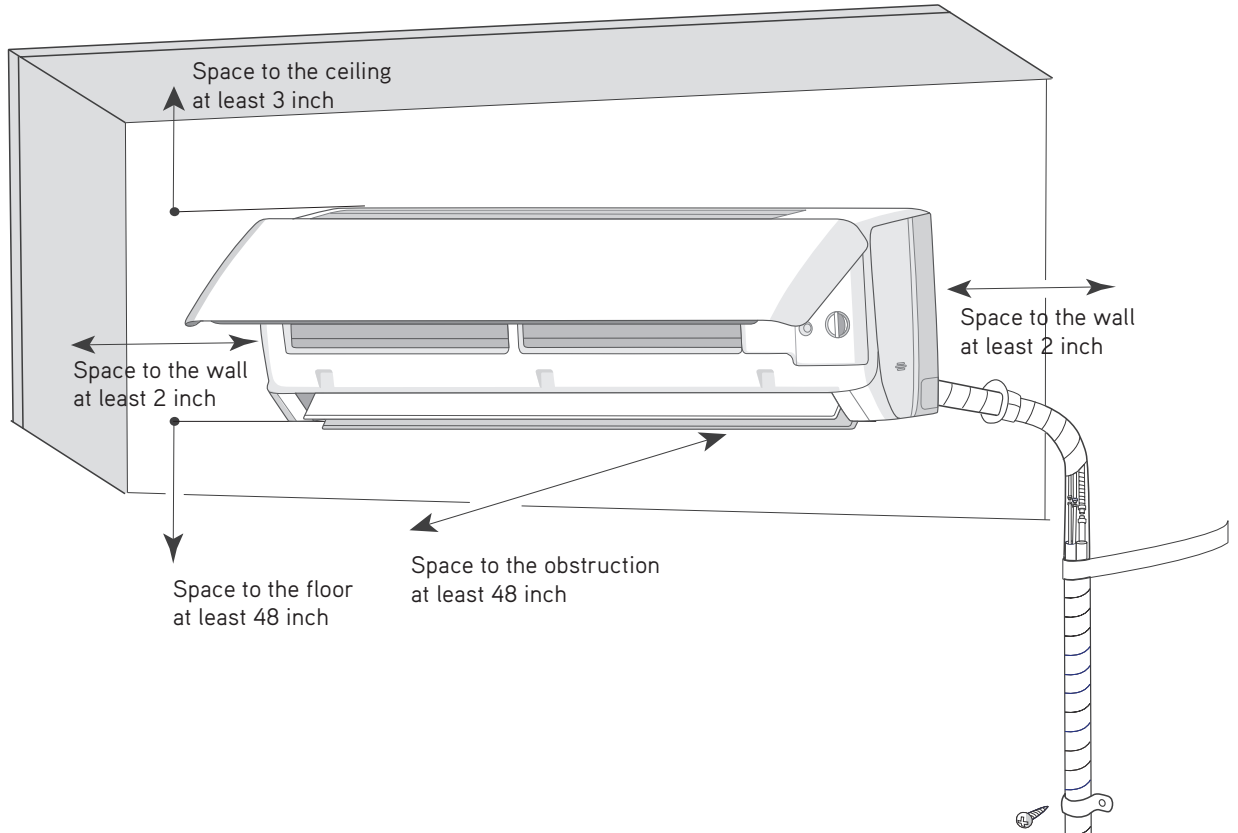

## OUTDOOR UNIT Minimum clearance

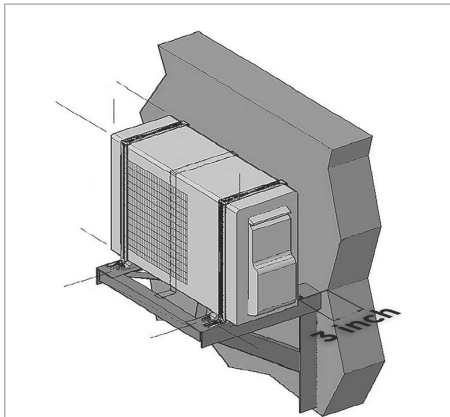

### NOTE:

If bottom of the unit is free of airflow obstructions similar to the mounting bracket figure, the clearance to the wall on the back can be reduced to 3 inches.

